

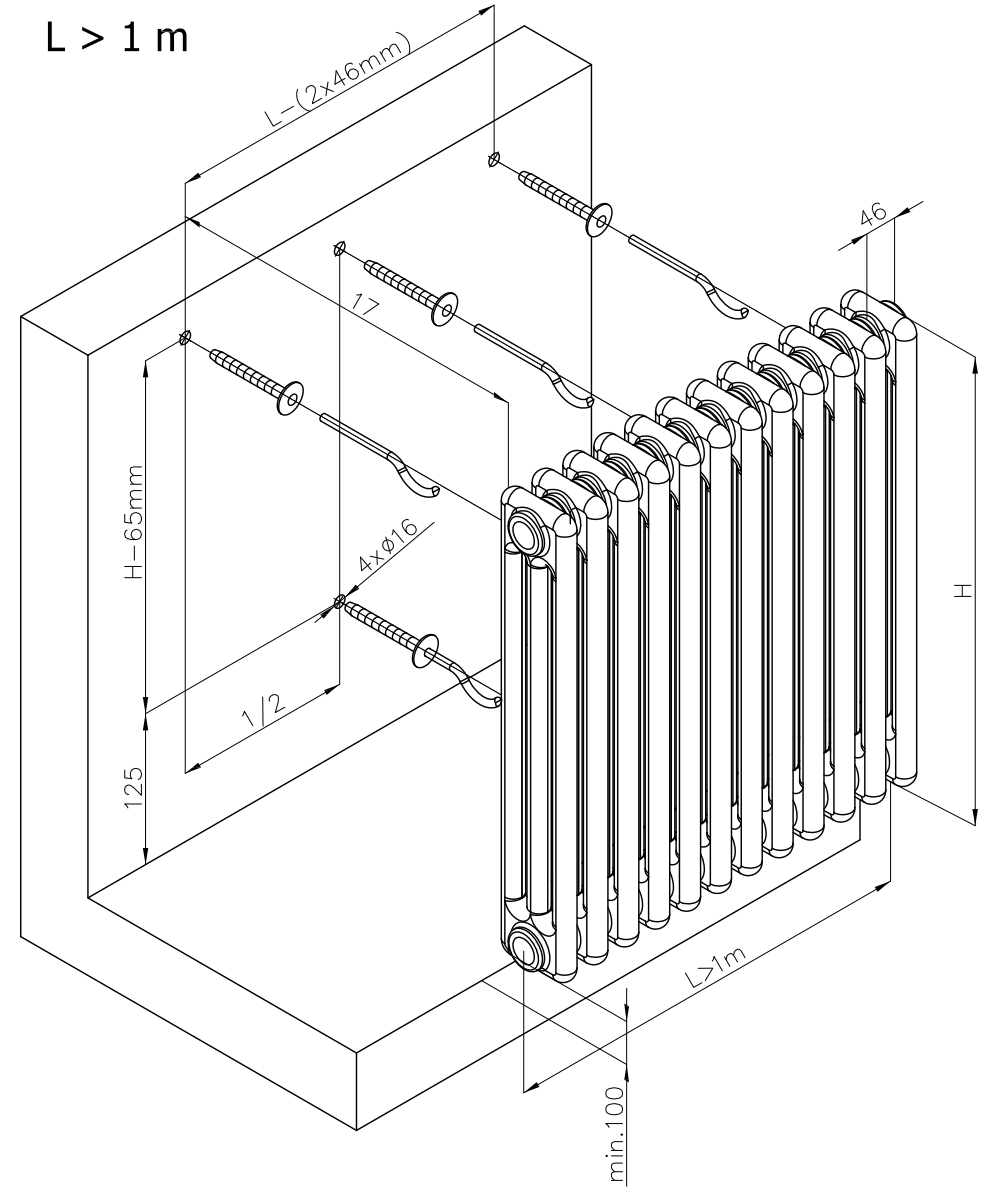

ATOL

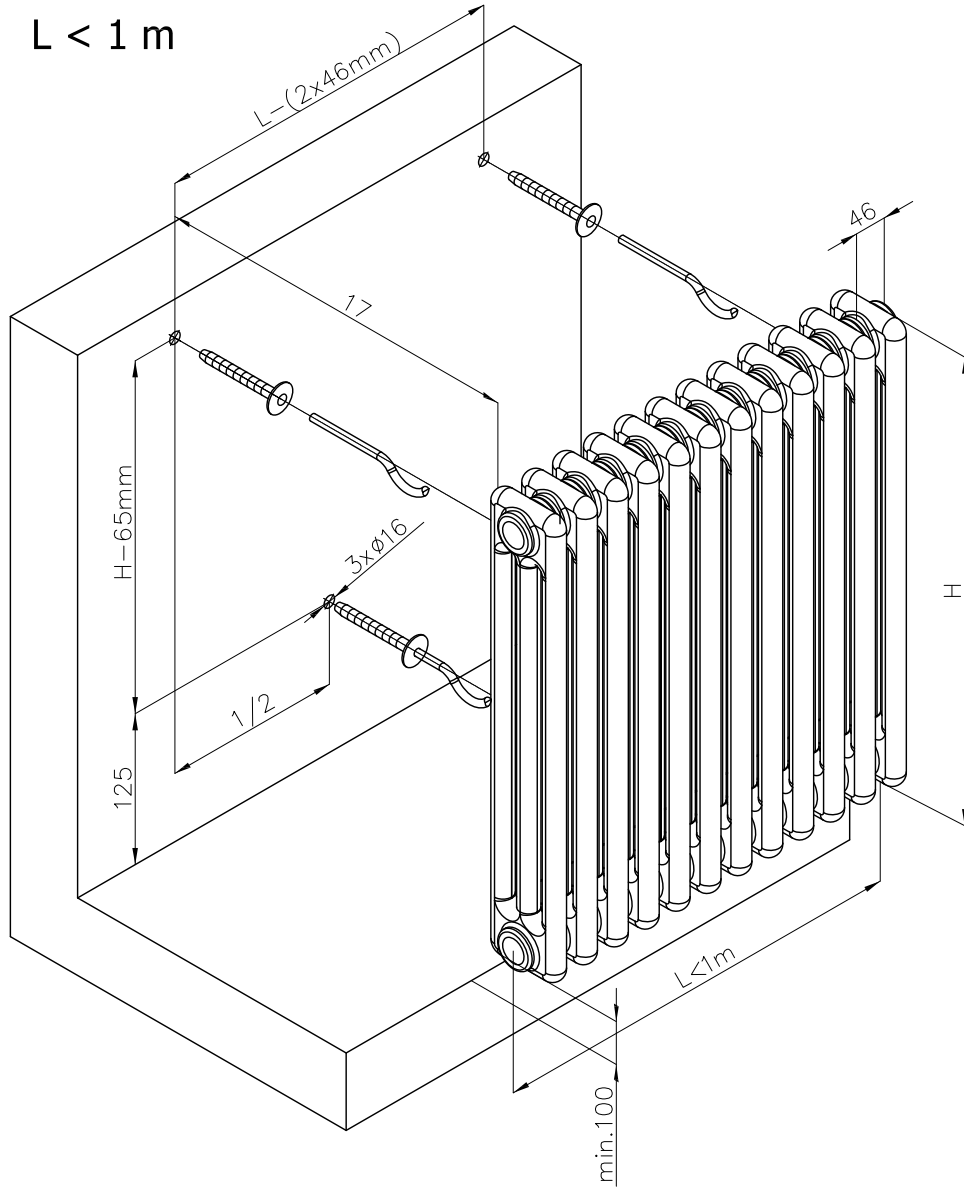



ATOL

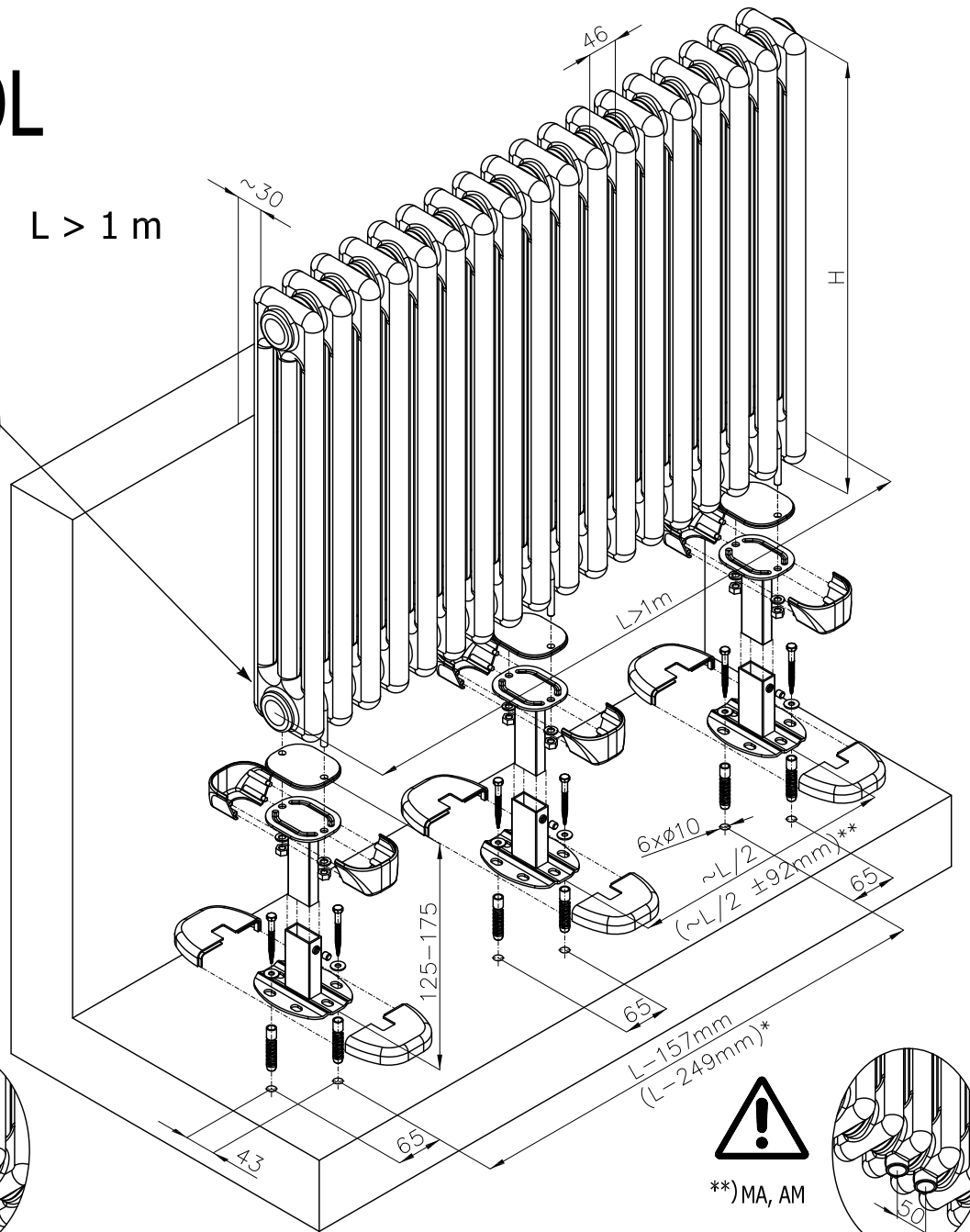
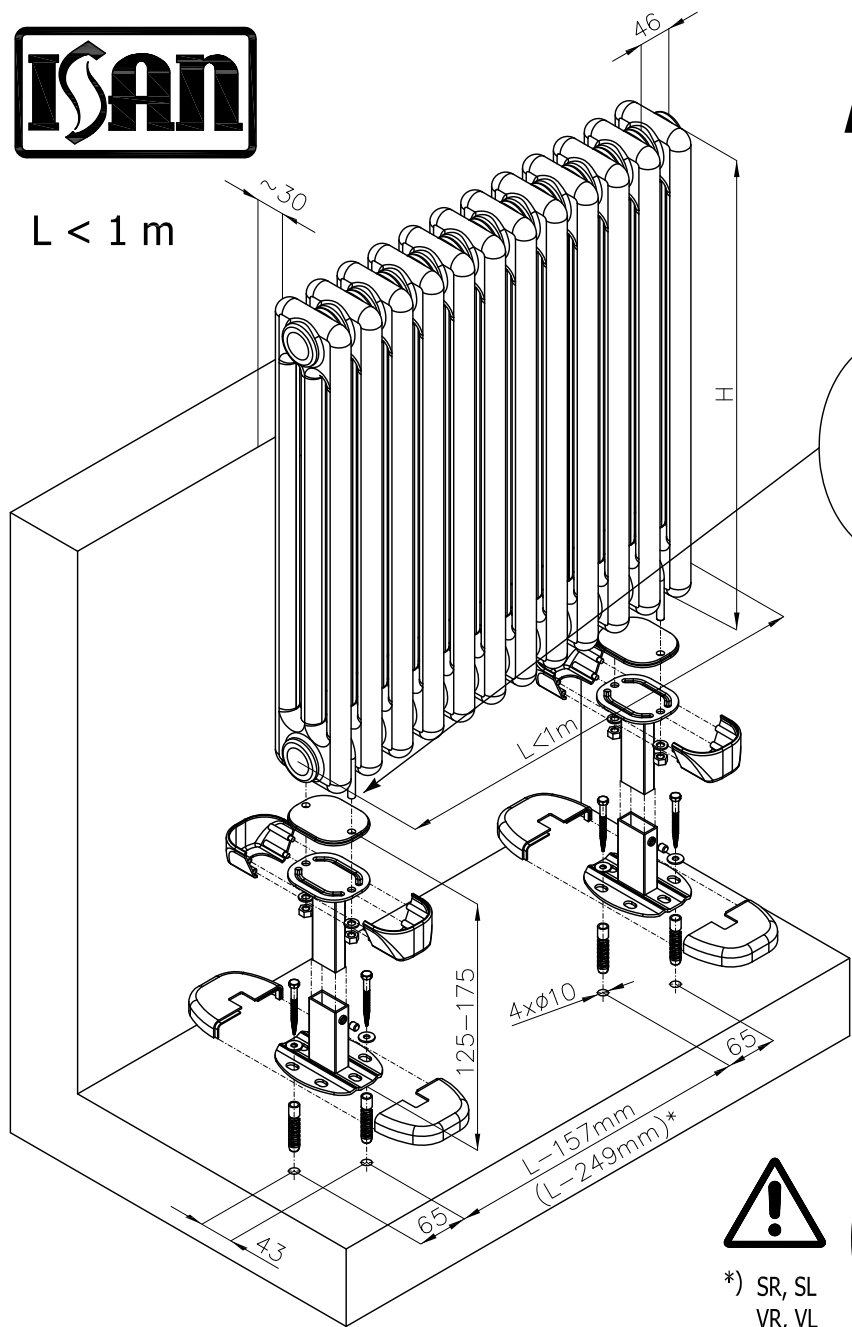

*) SR, SL
VR, VL
EF, FE

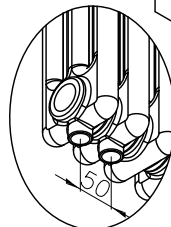

**) MA, AM





H < 1000 mm

ATOL

H > 1000 mm

*) Nr. E < 6

*) Nr. E < 6

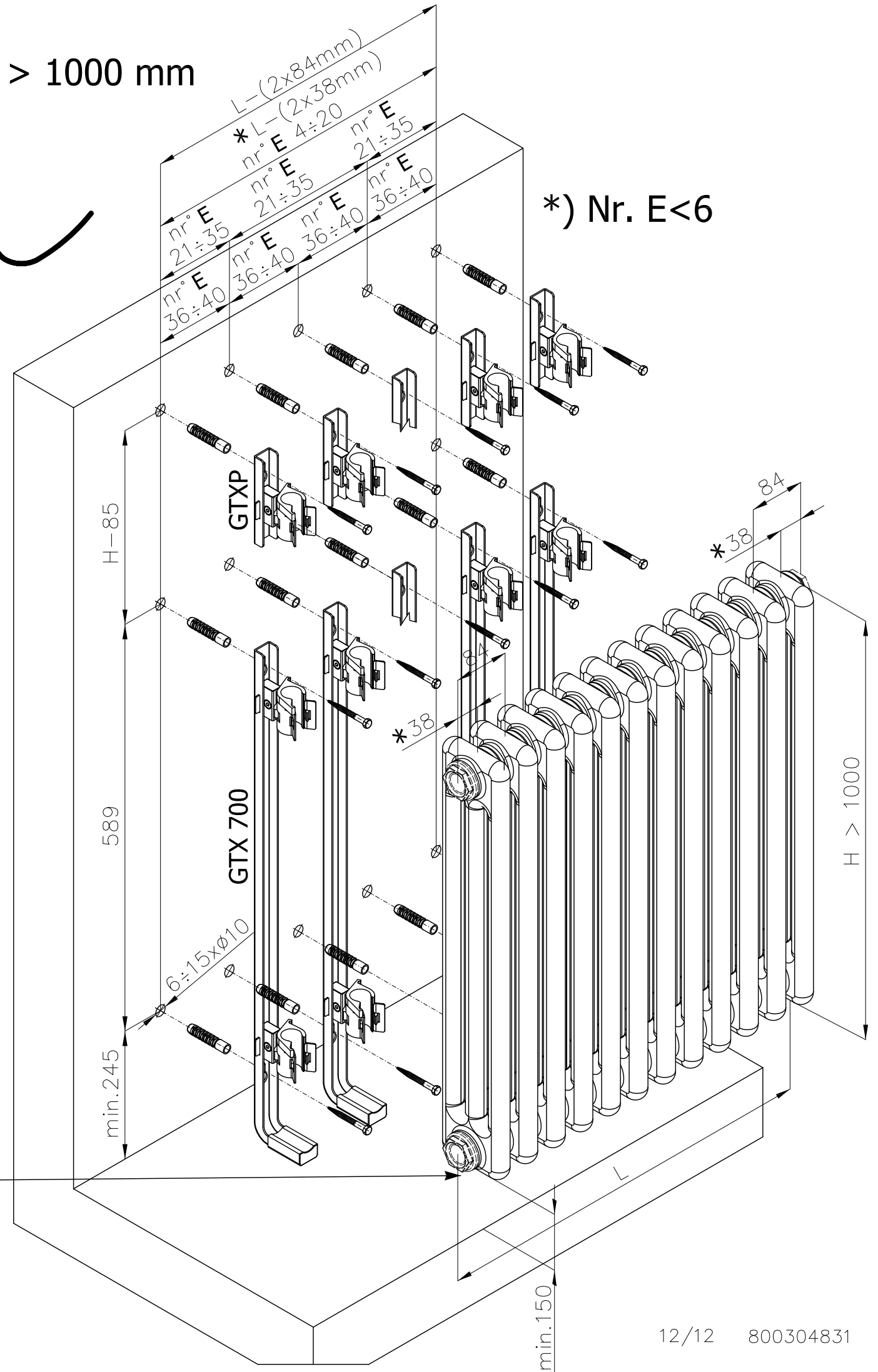
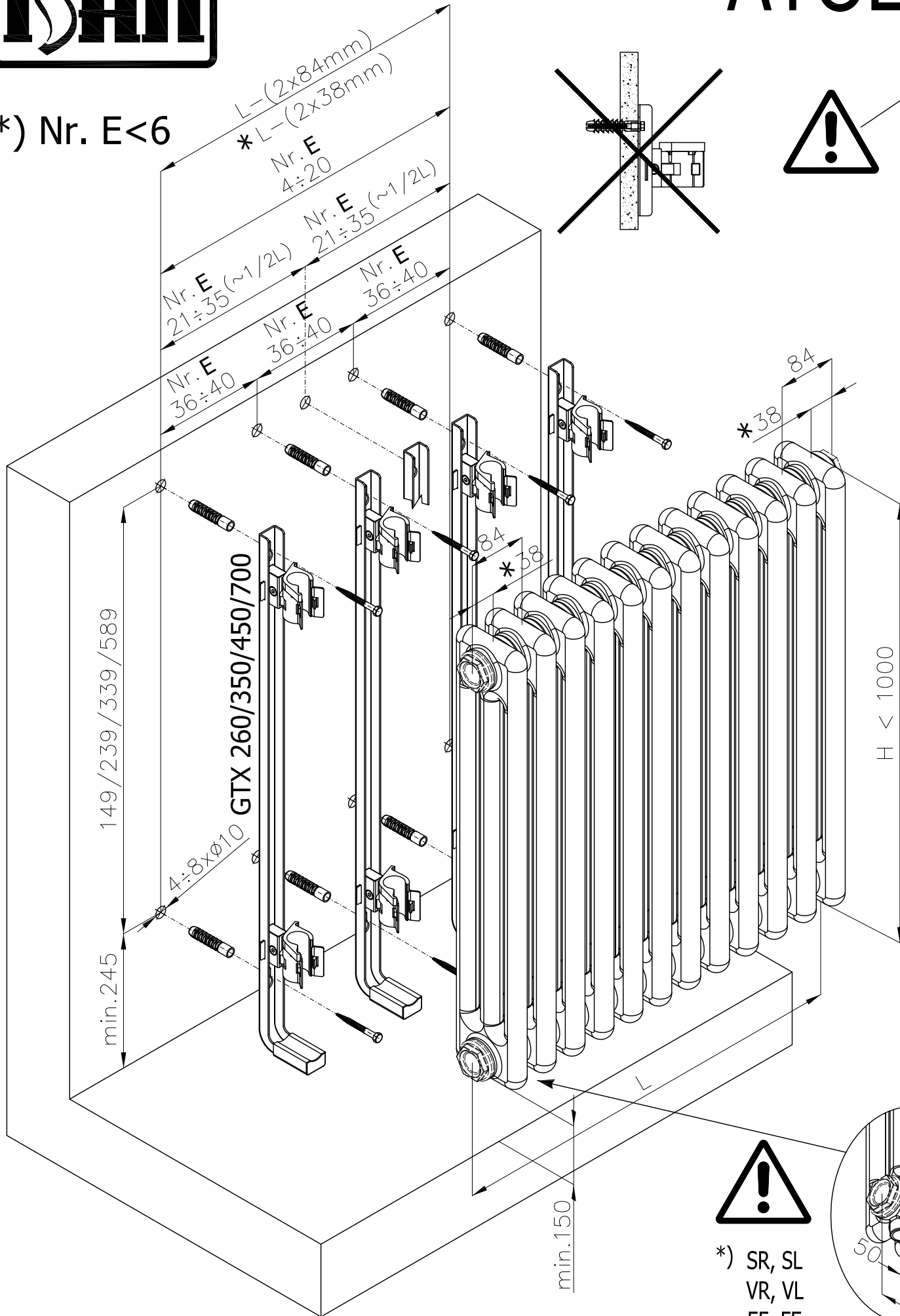

*) SR, SL
VR, VL
EF, FE

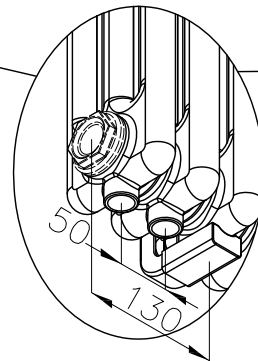

GTX 260 (H min300 - max350)

Nr. C	Nr. E		
	4 ÷ 20	21 ÷ 35	36 ÷ 40
2	2	3	4
3	2	3	4
4	2	3	4
5	2	3	4
6	2	3	4

GTX 350 (H min350 - max450)

Nr. C	Nr. E		
	4 ÷ 20	21 ÷ 35	36 ÷ 40
2	2	3	4
3	2	3	4
4	2	3	4
5	2	3	4
6	2	3	4

GTX 450 (H min500 - max700)

Nr. C	Nr. E		
	4 ÷ 20	21 ÷ 35	36 ÷ 40
2	2	3	4
3	2	3	4
4	2	3	4
5	2	3	4
6	2	3	4

GTX 700 (H min750 - max1000)

Nr. C	Nr. E		
	4 ÷ 20	21 ÷ 35	36 ÷ 40
2	2	3	4
3	2	3	4
4	2	3	4
5	2	3	4
6	2	3	4

GTX 700 + GTXP (H min1100 - max2200)

Nr. C	Nr. E		
	4 ÷ 20	21 ÷ 35	36 ÷ 40
2	2	4	5
3	2	4	5
4	2	4	5
5	2	4	5
6	2	4	5

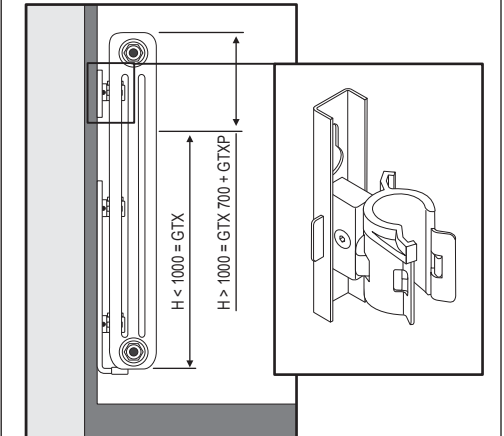
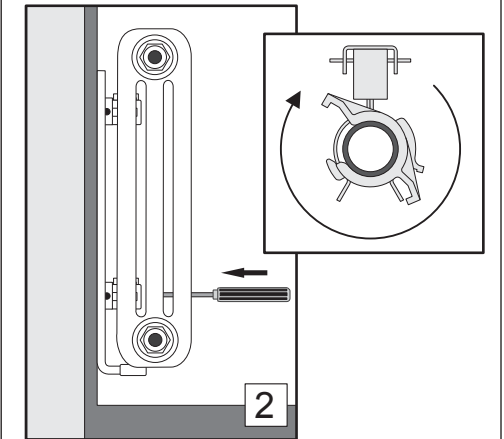
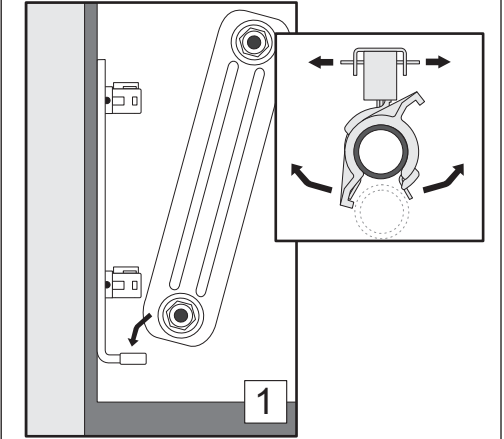
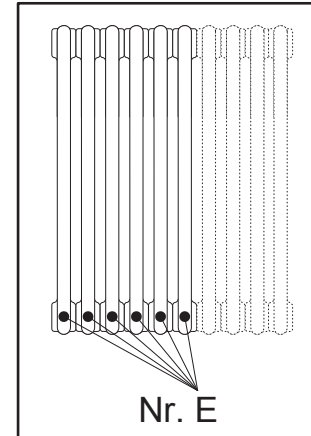
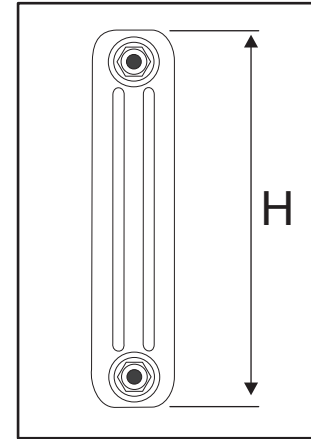
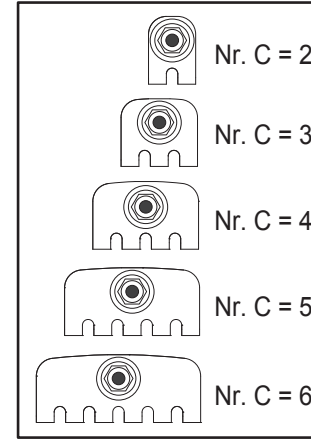

ATOL LAVICE

